

## **Flexible prototype board design for ADC/DAC control: application to mini-projects.**

**Samuel Lakeou Ph.D.**  
*Department of  
Electrical Engineering  
University of the District of Columbia*  
[slakeou@udc.edu](mailto:slakeou@udc.edu), (202) 274-5834

### **I. Introduction**

This paper describes a practical approach to the development of mini-design projects for junior and senior electrical engineering students. The mini-projects utilize the design of a prototype board for controlling an 8 or 12-bit analog-to-digital controller (ADC) and an 8 or 12-bit digital-to-analog controller (DAC). The work emphasizes the judicious use of the input/output (I/O) capabilities of an Intel-based personal computer (PC) for providing a very flexible and useful ADC/DAC controller circuit. The controller, which functions as an elementary data acquisition board, is built on an off-the-shelf prototype breadboard, which is installed on an **EISA<sup>1</sup> (Extended Industry Standard Architecture)**, 8MHz @ 8/16/32 bits data bus, 32 bit address, bus slot on the PC. The design allows for flexible use of the signals of the EISA bus for various design applications such as a simple digital proportional-integral-derivative (PID) control system and an **ultrasonic ranger** and **RC Servo** control circuit. The various design applications can constitute a series of mini-projects that can be tailored to several courses such as senior project, junior design etc...The ADC/DAC controller was used with a variety of application circuits at UDC. After a description of the controller board, the paper highlights the example of the design of a controller of an Ultrasonic Sonar Transducer and an RC Servo for range sensing application. The paper describes also the versatility of the design as well as its cost effectiveness. It illustrates the ease with which the design can allow students to use their computing skills as well as their hardware design skills. The paper also proposes the implementation of the controller design with a VHDL-based, complex programmable logic circuit (CPLD).

### **II. Description of the controller circuit.**

The DAC/ADC controller board comprises the following circuit components as depicted in Fig. 1:

- a) An input/output interface block, which allows bi-directional data movement from the PC to the ADC or the DAC, as appropriate;

- b) A circuit for controlling the ADC;
- c) A circuit for controlling the DAC; and
- d) Various digital and analog input/output ports for process access through transducers.

The input output interface block allows for a buffered bi-directional 8 or 16-bit digital data transfer under the following conditions:

- Data will be transferred from the PC to the DAC when “written” at addresses between 300Hex to 31Fhex. During any write operation, the EISA bus will set IOW and AEN to 0 and IOR to 1.
- Data from the ADC, converted from the analog input, will be transferred to the PC when “read” at addresses between 300Hex to 31FHex. During the read operation, the EISA bus will set IOR and AEN to 0 and IOW to 1.

The addresses from 300Hex and 31FHex are reserved for prototype design. Therefore, any input/output activity will not interfere with other internal functions of the PC.

The ADC control circuit must guarantee some of the following requirements, common to most commercially available ADC's.

- Generation of a signal to latch in the ADC, the address of the selected analog input to be converted. The address of the analog input can be embedded in the I/O valid address selected for data transfer. Typically, the last three least significant bits: A0, A1, A2 from the EISA bus address lines are used for this purpose.
- Generation of a signal to start the conversion process (i.e. a START signal)
- Generation of an appropriate clock signal for timing the conversion process. The clock can be derived from the EISA bus clock of 8 Mhz
- A circuit for checking that the conversion is complete and retrieval of the converted value.

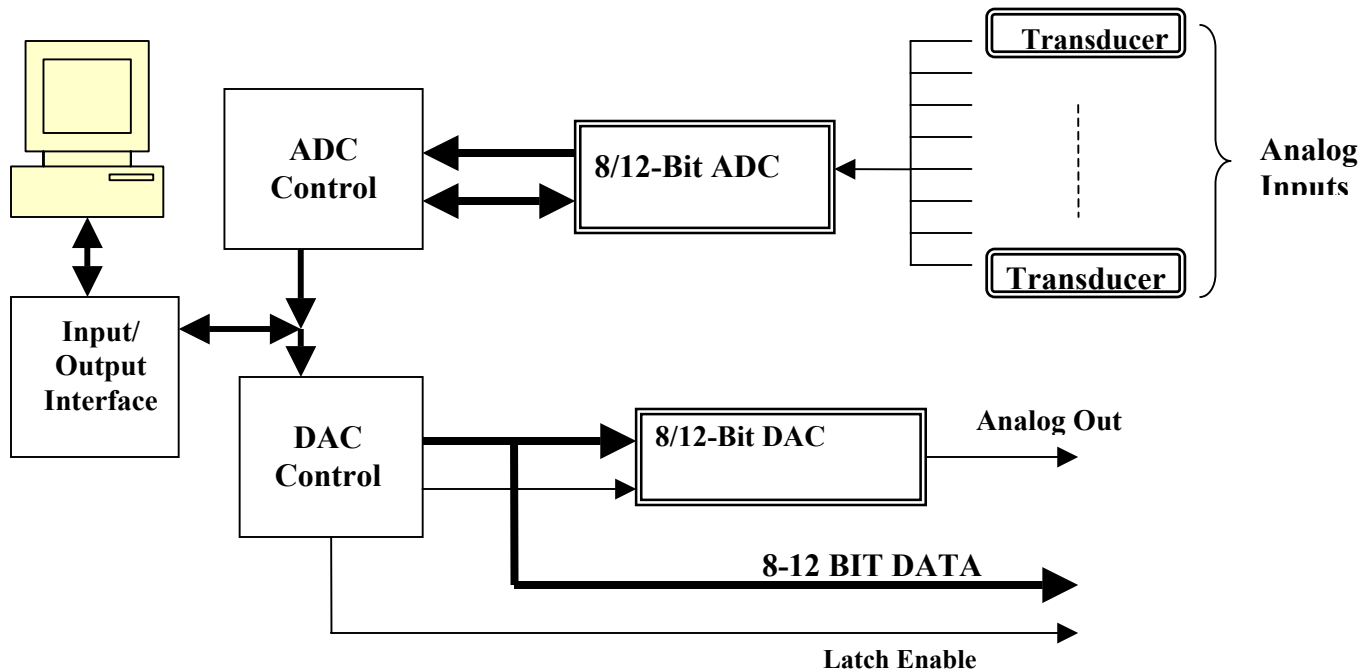

Figure 1. Block representation of the ADC/DAC controller

### III. Component level circuit description

The ADC/DAC was implemented in both off-the-shelf discrete component and programmable form, with a complex programmable logic device (CPLD).

#### a) Implementation of the circuit in discrete form.

The components are all TTL low power Shottky (LS) type. A bus-insertable prototype board is used for bread boarding the entire design. The schematic diagrams in Fig. 2 and Fig. 3 depict the entire circuit. The case of an 8-bit ADC (ADC0809) combined with 12-BIT DAC (AD667) design is described here. The 12-Bit DAC is used here in a *right-justified data* mode to interface with an 8-Bit bus. A DAC resolution of 1.22mv is expected.

All input and output signals as well as selected signals such as the clock signal, +/-5V, +/-12V power signals are made available through a DB25 connected to the prototype board.

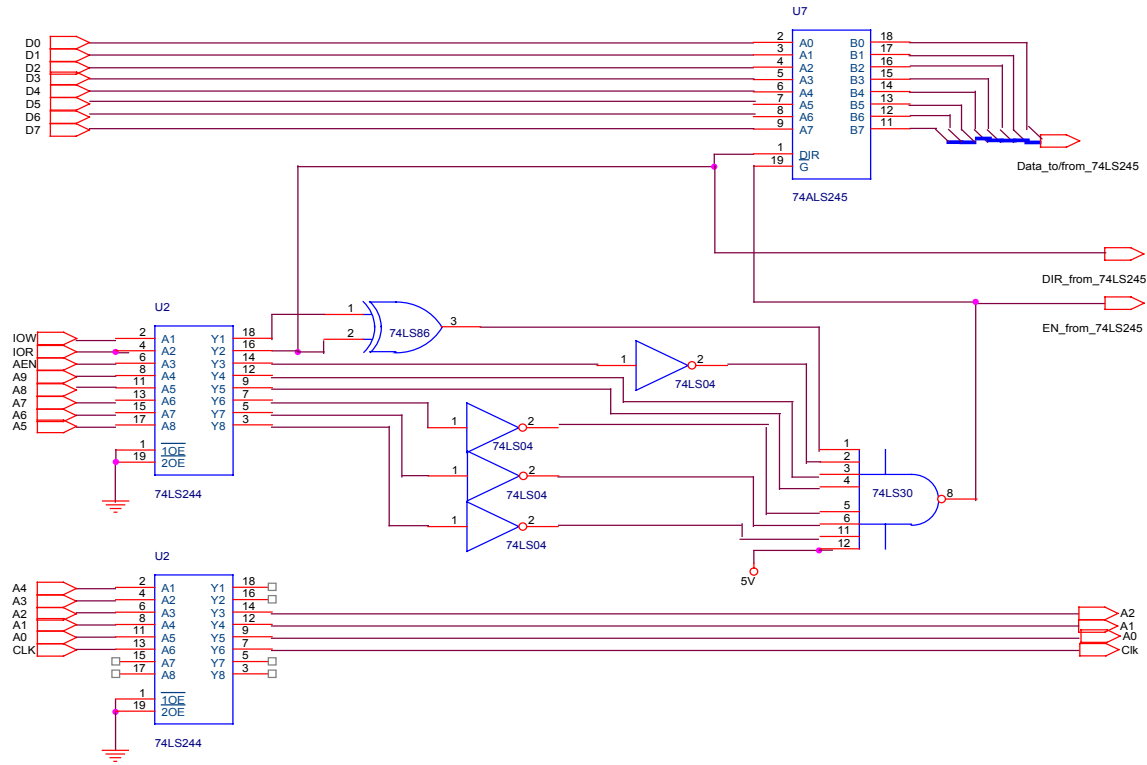

Figure 2. Schematic diagram of the input output interface circuit

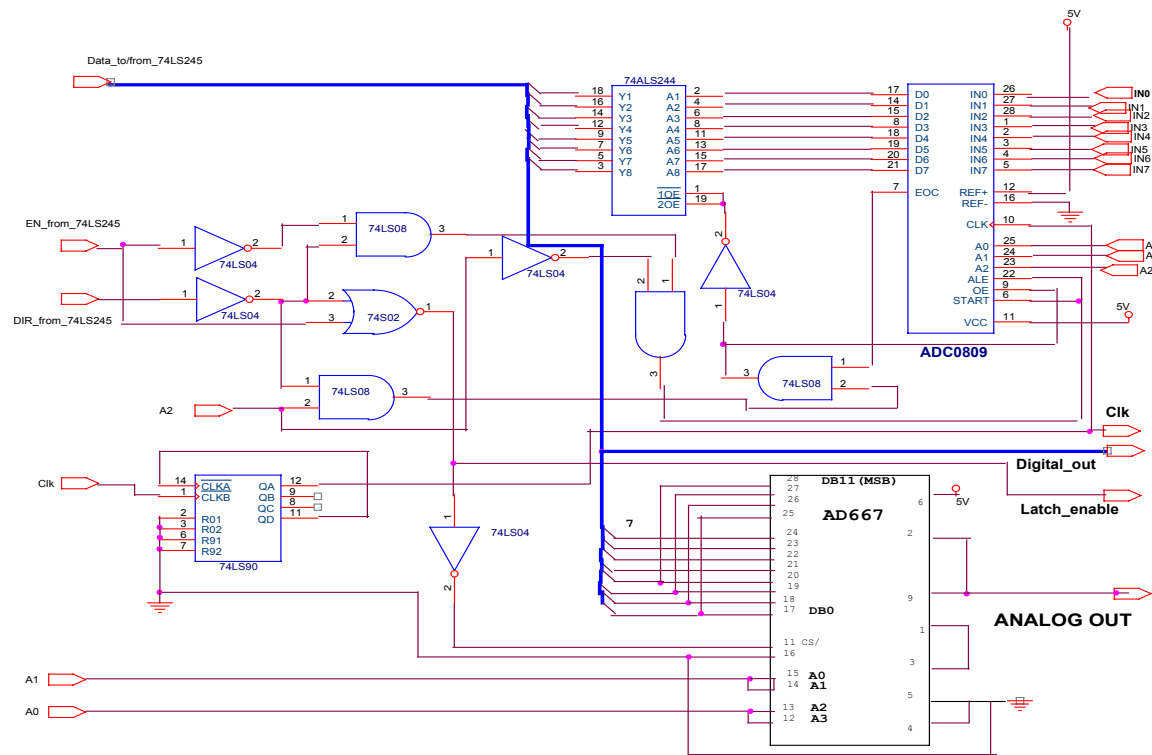

Figure 3. Schematic of the ADC/DAC control circuits

The final prototype breadboard is shown in Fig 4.



Figure 4. Prototype breadboard (left) of the ADC/DAC controller circuit inserted in the EISA bus slot of the PC (right).

b) Implementation of the circuit with a complex programmable logic device (CPLD).

The selected CPLD is an 84-pin Xilinx XC95108<sup>2</sup> with 2400 usable gates and 69 user definable input/outputs. The process includes the following steps:

- Schematic capture of the design using the Integrated Software Environment (ISE) design environment of Xilinx<sup>3</sup> or description of the design using the VHDL code from ISE. In the latter case, entities are defined for every components of the design
- Simulation of the circuit using Modelsim<sup>3</sup>
- Synthesis of the design
- Programming of the XC95108 by downloading the design

Fig. 5 depicts the captured schematic of the design and Fig. 6 shows the “programmed” version of the design. The Xilinx XC95108 CPLD was programmed directly from the PC through its parallel port as per the programming procedure provided by Xilinx<sup>3</sup>

#### IV. Programming considerations

The ADC/DAC controller board is “driven” by a project-dependent program, which can be written, in one of the following languages:

- High-level program such as C++, Visual BASIC, Fortran
- Assembly Language compatible with Intel microprocessors (Macroassembler)
- Machine Language

For most projects, the language selected is the Assembly Language programming with the Debug programming tool available on all IBM compatible PC's.

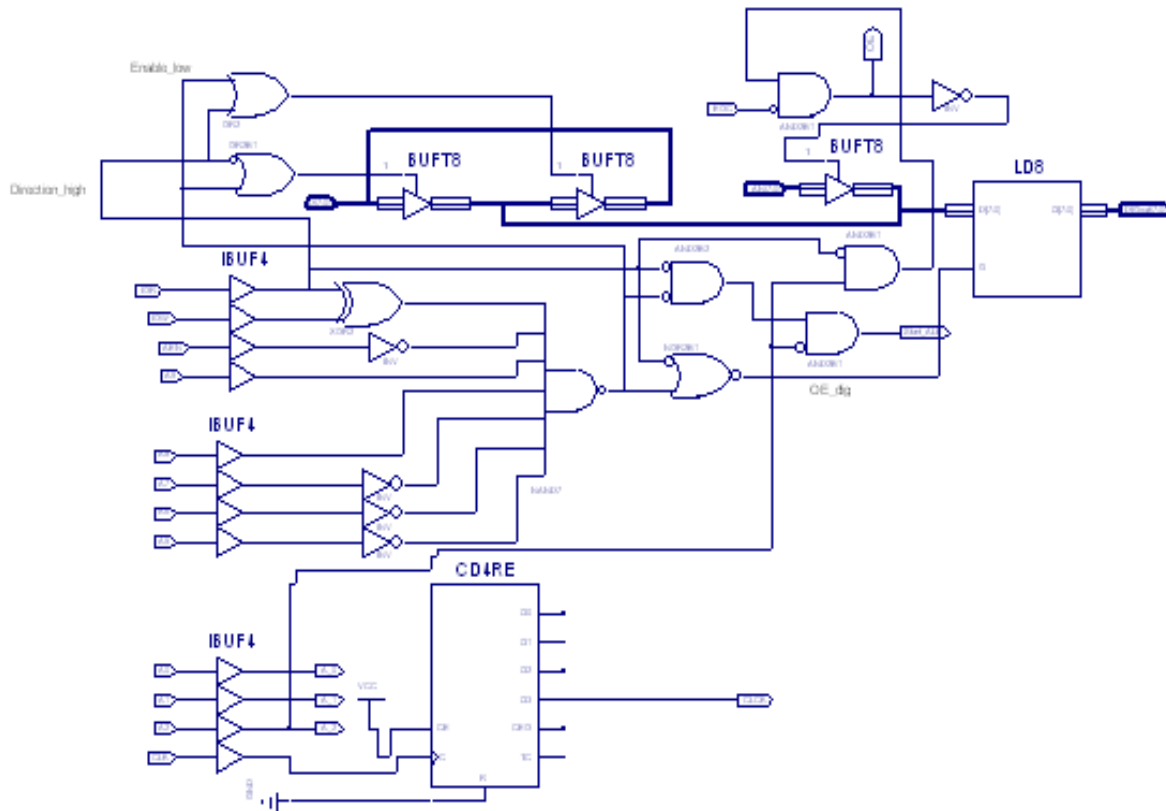

Figure 5. Schematic of the “programmed” circuit



Figure 6. “Programmed” version of the controller circuit using the XC95108 CPLD

The Debug program is the preferred tool for assembly language programming of relatively short programs. It is factory provided on any IBM compatible PC and has a built-in assembler<sup>4</sup>, which has a very practical debugging capability. A macro assembler such as the MASM is also suitable.

The following set of programming commands provide basic input output data control on the board.

- Commands for sending (outputting) an 12-bit data to be converted into an analog voltage:

```
MOV DX,301 ; put port address in register DX to activate lower latches in the DAC
MOV AL,FF ; put in AL, the lower 8-bits LSBs, "FF" of the 12-bit data to be converted
OUT DX,AL ;send out the data at selected port address
MOV DX,302 ;put port address in register DX to activate higher latches in the DAC
MOV AL,0F ; put the upper four bits digital data "0F" of the 12-bit data to be converted in AL
OUT DX,AL ; send out the data at selected port address
```

- Commands for converting an analog data into an 8-bit digital data to be read by the PC:

```
MOV DX,300 ;put the port address as well as the "embedded" input address "000"
IN AL,DX ;do a "dummy" read to latch the address of the input selected and provide the
;START signal to start the conversion process
MOV DX,304 ;put a new port address for allowing the converted value to return to the PC
;it is expected that enough data conversion time will be elapsed here (~100us
;for the ADC0809 8-bit ADC). If more time is required, an optional delay
;such as looping may be added here before proceeding to the next command
IN AL,DX ;read the converted signal and place it in the register AL
```

Note that these commands are compatible with the hardware design of the controller and prevent any interference through bus conflict, between DAC and ADC operations.

Other project dependent commands, such as keyboard check and process dependent data manipulation can be developed using the rich command instruction set of Intel microprocessors<sup>4</sup>. Students are encouraged to develop a friendly user interface for running their programs.

## **V. Application of the DAC/ADC controller as an RC servo and an ultrasonic ranger control circuit.**

An ultrasonic sonar transducer (UST, MUSTA 8v-12V)<sup>5</sup>, acting as a "target-distance to voltage transducer" is carried by a radio controlled (RC, MS492)<sup>5</sup> servo sweeping an angle spanning 90 degrees. The voltage to target distance dependence is calibrated with the UST to produce a voltage of 0V for the closest detectable target (occurring at around 0.5m) and 5V when the target distance exceeds 2 meters. For the selected RC servo, the voltage is inversely proportional to the target distance.

A pulse width modulated (PWM) signal with a period T between 17 to 20 ms applied to the RC

servo allows for the following:

- Pulse width of 1ms: First Extreme Position

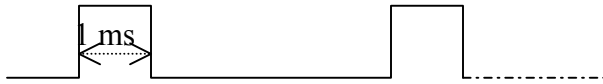

$$17\text{ms} < T < 20\text{ms}$$

- Pulse width of 2ms: Second Extreme Position



The RC servo PWM input is connected to the analog out of the prototype board. The voltage output of the UST is connected to analog input IN0 of the ADC. Figure 7 depicts the RC-servo/UST assembly.



Figure 7. RC servo -Ultrasonic Sonar Transducer assembly

The project is specified to produce a warning signal when a target is detected at a distance of about 1m.

The ADC/DAC board is therefore required to achieve the following:

1. Produce a PWM signal to control a continuous 90 degree sweep of the RC servo;
2. Detect the voltage output of the UST;
3. Check if the voltage level is 2.5V (level corresponding to a critical position of the target at a distance of 1m);
4. Provide a warning signal to be displayed on a light emitting diode; and
5. Interrupt the process when any key is pressed on the keyboard.

The PWM signal is generated by the DAC. The DAC receives a 12 bit digital value of FFF in Hex (i.e. 111111111111 in binary), which it converts into a 5V signal. The signal is kept at 5 V for a desired period of time (1ms or 2ms) and is generated periodically every 17 to 20 ms. The modulation of the signal is achieved through various programmed looping schemes. The RC servo is therefore controlled to sweep continuously a span of 90-degree angle.

The detection of the output voltage of the UST is made with the ADC. The voltage is continuously converted into its corresponding digital value. The converted value is periodically checked against a reference value representing 2.5V. If the value is less than 2.5V, a digital signal will be sent on any selected digital output line and latched in an external latch, to activate a light emitting diode. The LED will be turned off as soon as the target is removed from the critical position and that the UST voltage remains larger than 2.5V. The sweeping process of the RC servo and the UST's target detection will remain active until a key is pressed on the keyboard of the PC.

## **VI. Benefits of the prototype board.**

### **a) Flexibility**

The ADC/DAC board is a simple data acquisition (DAQ) board, which can be used in variety of project settings. The following are some project areas, which could make use of the board:

- Single Loop Digital Process Control, including PID controller design
- Programmable Controller Design (including high voltage relay control)
- Digital Signal Processing
- Sensor/Transducers and Actuator Controller Design, Robotics

Data acquisition, data conditioning and control data generation are essential features required in most projects. Many companies, such as National Instruments have a variety of data acquisition boards driven by a slew of high-end software packages such as Labview<sup>7</sup>. The features provided by these boards are often very sophisticated and sometimes overwhelming for designing simple projects, which emphasize a hands-on approach.

By contrast, students in a mini-project setting can build the proposed ADC/DAC board from scratch and grasp with relative ease the concept of data flow and data conversion. They will also have a better appreciation of the timing requirements during data sampling and data generation. The board design, including prototype building and testing can be achieved in less than one third of a 2-Credit project course, as part of a mini-project assignment. The remainder of the mini-project assignment can be devoted to interfacing the ADC/DAC board to a selected external circuit. The breadboard can be also be disassembled for future use.

### **b) Multidisciplinary Nature**

The ADC/DAC controller board is applicable to projects developed in the following disciplines:

- Electrical/Computer Engineering.

- Computer Science.
- Mechanical Engineering.
- Mechatronics/Robotics.

The interaction between students in the aforementioned disciplines can occur at various levels. For example, a student majoring in computer science can develop an appropriate graphic user interface (GUI) for the project on hand. Students in mechanical engineering can be involved in outlining the basic force, torque requirements for proper control of a given mechanical device. The discipline of mechatronics, which depends heavily on the use of microcontrollers, can also benefit from the use of the board. The PC can emulate most of the features of the microcontroller.

### c) Cost

The total cost of the board is less \$150 and far below that of commercially available DAQ boards. The following Table 1 is a breakdown of the price of various components required for building the board.

It is to be noted that most TTL and linear parts can be obtained from the manufacturers such as National Semiconductor and Texas Instruments as evaluation parts.

Part	Price (USD) (Total: 144.37)	Comment
8-16 Bit solder-less breadboard card	57	Suggested vendor: Jameco.com
TTL-components and miscellaneous components	14	
ADC (8 Bit, ADC0809)	1.84	Evaluation part available for free from National.com
ADC (12-Bit) AD1241	6	
DAC (8-bit, DAC0800)	0.53	Evaluation part available for free from National.com
DAC (12-bit, AD667)	15	
Wire kit	15	
Xilinx XC95108 CPLD	35	Used in the Programmable version of the Board*
Driver software	0	If the Debug assembler is used.

\*The ISE software for programming the CPLD can be acquired from the Xilinx University Program<sup>5</sup> (XUP) for a yearly maintenance fee of about 250USD.

Table 1. ADC/DAC board cost summary

## VII. Conclusion

The ADC/DAC board has demonstrated its usefulness through several successful student projects over the last few years at UDC. The board design combines traditional digital circuit design with state-of-the-art design methodologies (VHDL). Its simplicity, its versatility and its cost effectiveness should make it attractive to many various engineering and computer science disciplines requiring data acquisition and manipulation, and system/circuit control.

## References

- [1] EISA card pinout at [http://www.interfacebus.com/Design\\_PC\\_EISA\\_Card.html](http://www.interfacebus.com/Design_PC_EISA_Card.html)
- [2] XC95108 properties at [http://xilinx.com/xlnx/xil\\_prodcart\\_product.jsp?title=xc9500\\_page](http://xilinx.com/xlnx/xil_prodcart_product.jsp?title=xc9500_page)
- [3] Xilinx ISE 6 Foundation in depth tutorial at [http://direct.xilinx.com/direct/ise6\\_tutorials/ise6tut.pdf](http://direct.xilinx.com/direct/ise6_tutorials/ise6tut.pdf)
- [4] IBM PC Assembly Language & Programming, Peter Abel, Prentice-Hall
- [5] Xilinx University Program at <http://xilinx.com/univ/index.htm>
- [6] RC servo & Ultrasonic Sonar Transducer at <http://mrrobot.com/>
- [7] Labview at <http://www.ni.com/dataacquisition/>

## Bibliography

### Samuel LAKEOU

Samuel Lakeou received a BSEE (1974) and a MSEE (1976) from the University of Grenoble (Universite Joseph Fourier), and a PhD in Electrical Engineering from the Ecole Nationale d'Electronique et de Radioelectricite de Grenoble of the National Polytechnic Institute of Grenoble, France, in 1978. He is currently a Professor and Chairperson of the department of Electrical Engineering at UDC. He was formerly a staff member at the New Products Laboratory of RCA's Consumer Electronics Division in Indianapolis, IN (1984-86).